

GRC 101 INTRODUCTION TO GRAPHIC COMMUNICATIONS

Information
Sheet No.

709

INDESIGN TECHNIQUES

Getting the Most out of Guides

Everything you could possibly want to know about working with InDesign guides

If you're used to other layout applications, you may be unaware of all the things you can do with ruler guides in InDesign. In this tip you'll learn everything you could possibly need to know about the subject, including locking, snapping, copying and pasting, layer management, stepping and repeating, aligning and more. If you use guides in your work (if you're not you should), read on.

Controlling ruler guides: numeric positioning

Have you ever wished you numerically control the position of a ruler guide? In InDesign you can do exactly that.

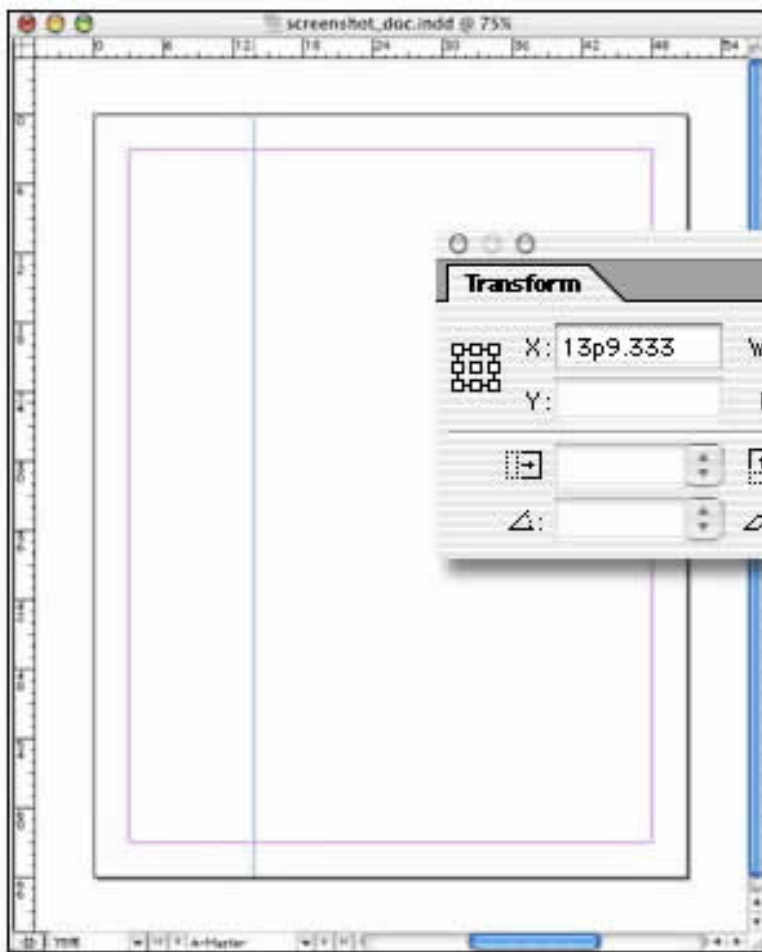

1. Use any tool to click on your horizontal or vertical ruler to drag out a ruler guide. With the guide still selected, note that either the X or Y coordinate will display in the Transform palette.

2. With the ruler guide selected, enter different values in the Transform palette and note that in InDesign you can control the position of a ruler guide numerically, not by just by dragging and dropping the guide. This feature gives you much greater levels of precision and control over the positioning of your ruler guides.

Controlling ruler guides: snapping to objects

For a quick way to snap a ruler guide exactly to the edge of an object on your page, check out this little shortcut.

1. Select the object to which you'd like to snap the ruler guide with the selection tool.

2. When you drag out a ruler guide, drag the two-headed cursor over one of the selected object's handles. This will snap the ruler guide exactly to the edge of the frame. There's no need to zoom into 4000% to verify that the guide is positioned correctly.

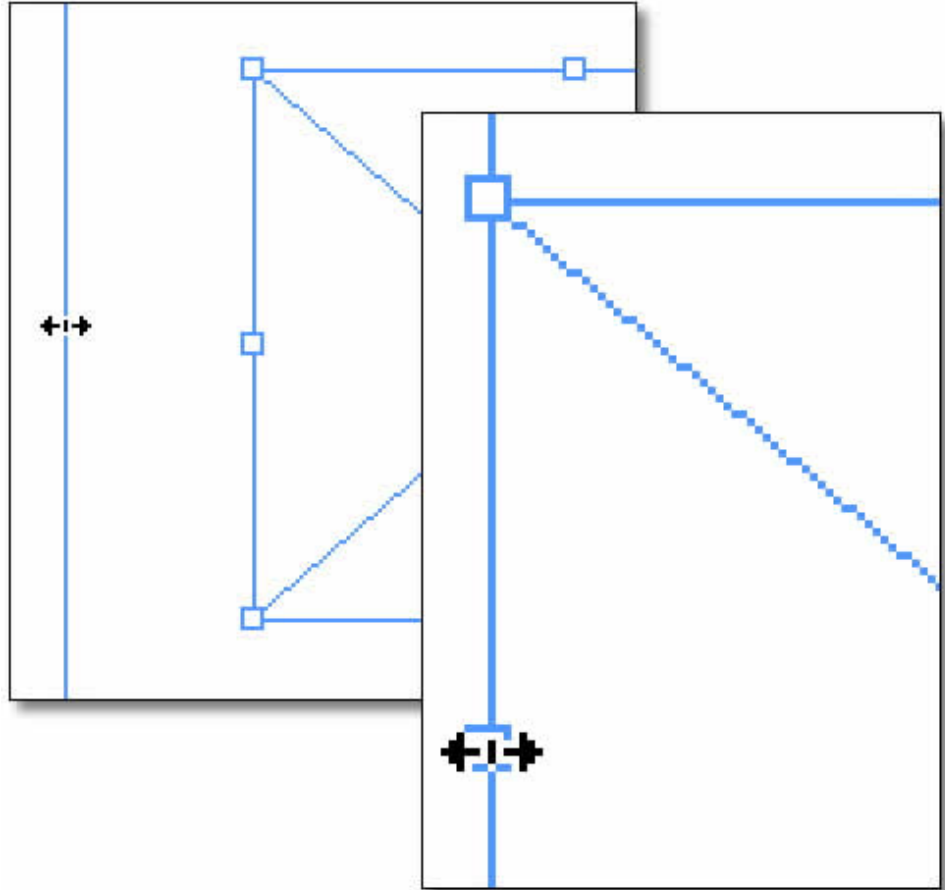

Controlling ruler guides: snapping to ruler ticks

A quick way to snap a ruler guide exactly to a specific tick mark on your horizontal or vertical ruler is to hold down the Shift key when you drag a ruler guide. Notice that it snaps to the ticks on the horizontal or vertical ruler. When you release the Shift key, the guide reverts back to the default behavior and doesn't snap to the ruler ticks.

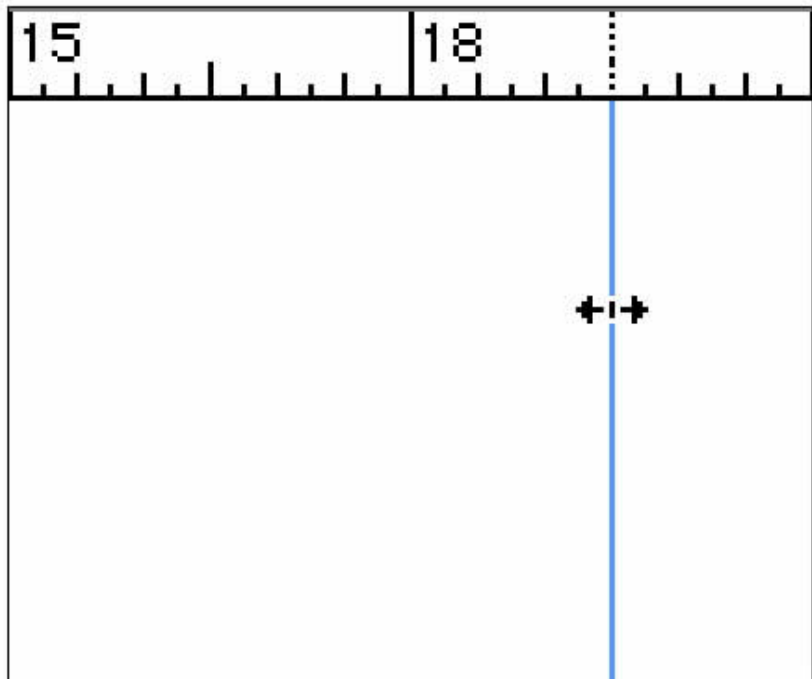

Controlling ruler guides: copy and paste

You can duplicate a set of guides on a different page or in a different document.

In InDesign, ruler guides are objects that you can copy and paste using the Clipboard.

1. Suppose you've created bleed guides out on your pasteboard on one spread and you'd like to have those same guides in another. One way to do this is to select the bleed guides you've created (more on fast, easy ways to do this later in this tip document), and use the Edit > Copy command.

2. Switch to the target spread in the same or different document, and use Edit > Paste to paste the ruler guides into the same position they had in the source spread. Note that if you're pasting guides into another document, the target spread needs to have same page dimensions in order for the original guide positioning to be maintained.

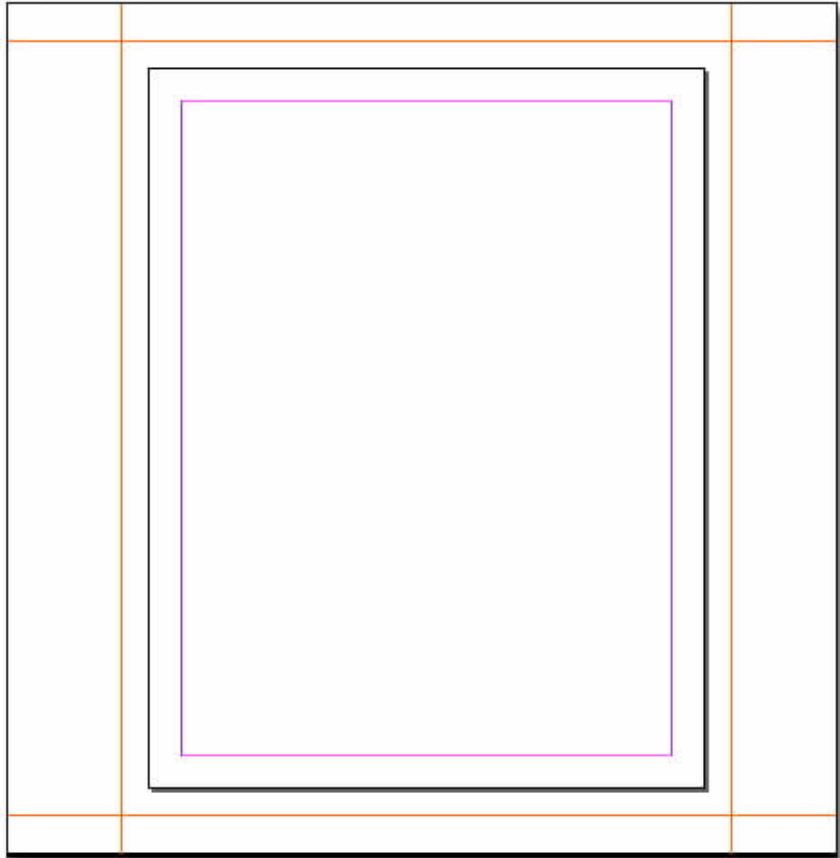

Controlling ruler guides: step and repeat

There is a quick way to create multiple guides with a fixed offset. Not only can you copy and paste ruler guides in InDesign, you can also use the Step and Repeat command, just like you would with any other object.

1. Drag a ruler guide on to your page.

2. With the guide still selected, go to Edit > Step and Repeat. You can then specify the number of guides you want to create as well as the horizontal or vertical offset desired.

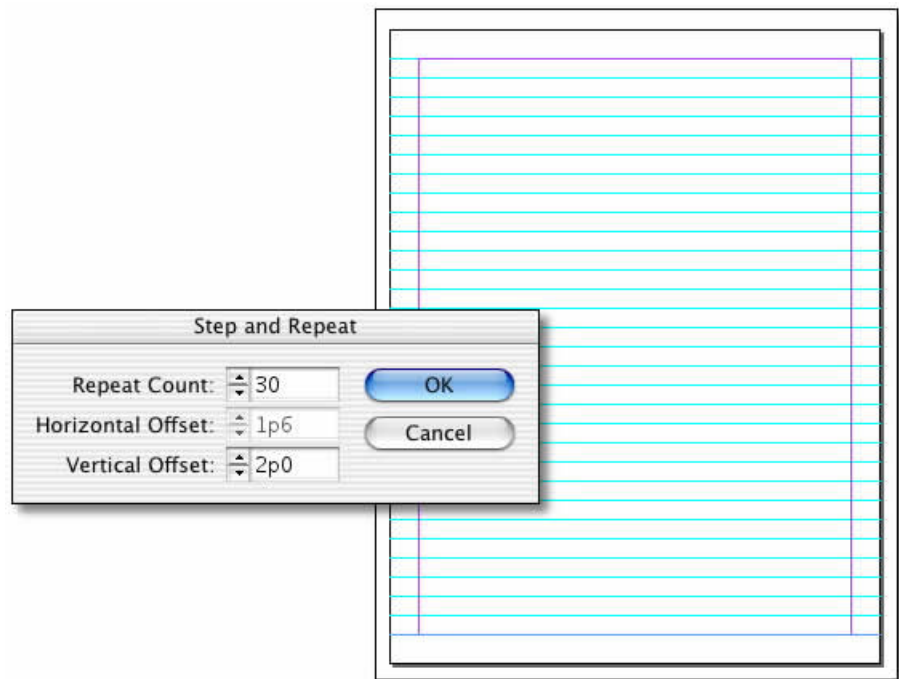

Controlling ruler guides: using the Align palette

If you need to distribute ruler guides in order to divide an area of your page into sections, InDesign enables you to do just that.

If you'd like to arrange some graphics in a manner similar to the example in the screen shot on the right. In InDesign it's easy to set up ruler guides to enable you to size and position the four image frames quickly and accurately.



1. Drag the appropriate number of ruler guides on your page.

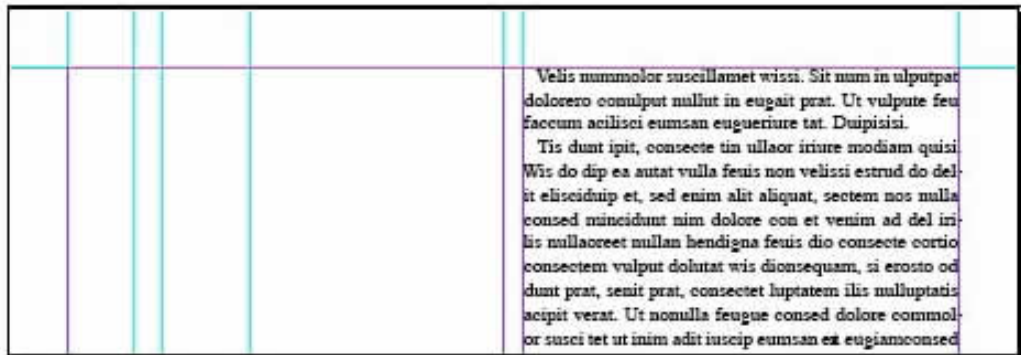

2. Select the ruler guides, and then distribute them using the buttons on the Align palette.

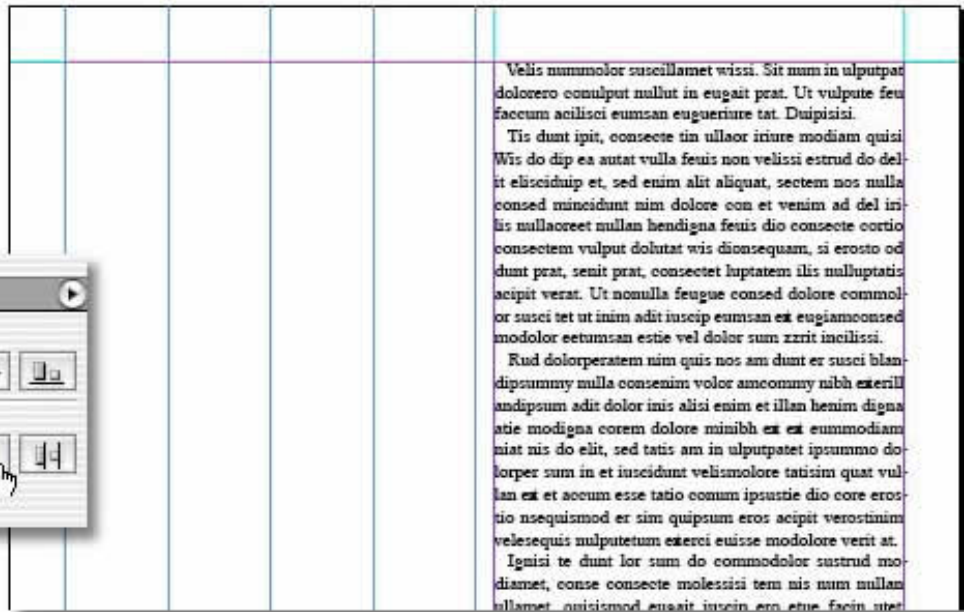
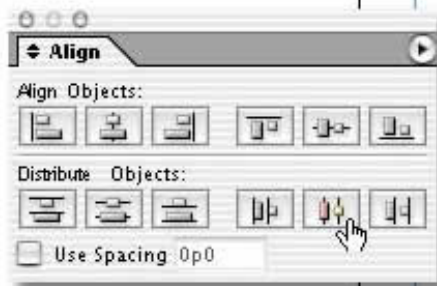

Color-coding your ruler guides

Upi can create different guides to do different things such as a page grid, plus another set of guides to position objects that aren't snapped to the page grid. You can color-code your ruler guides in order to visually identify which guides do what job. You can assign different colors to your guides on a guide-by-guide basis.

1. Select the ruler guides to which you wish to assign a new display

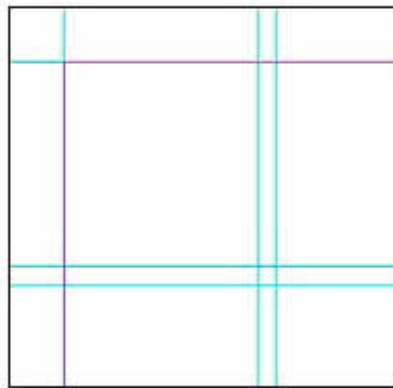

before: all the guides look the same

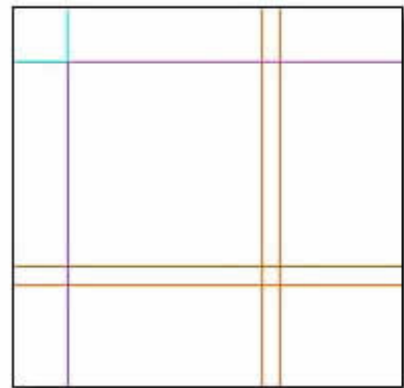

after: different colors for different functions

color.

2. Use Layout > Ruler Guides or the contextual menu to get to the Ruler Guides dialog box. There you can select the color you want for your ruler guides. before: all the guides look the same after: different colors for different functions.

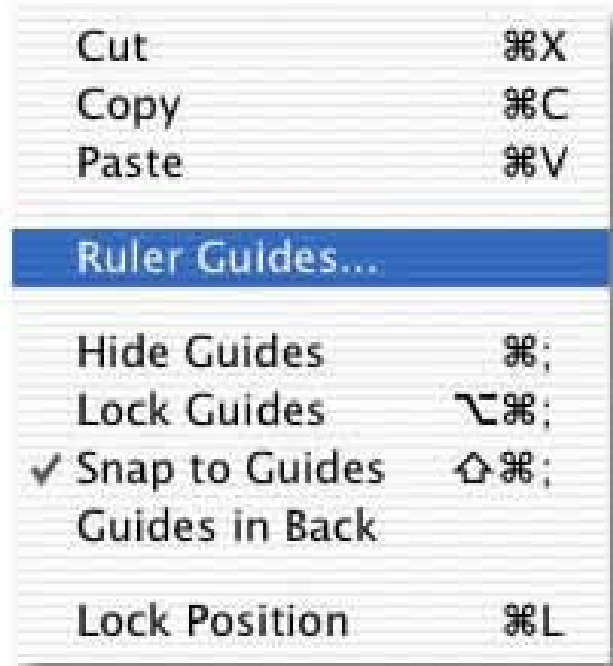

Locking individual ruler guides

You're probably used to having to either lock the position of either all or non of your ruler guides. InDesign gives you the flexibility of locking down your guides on a guide-by-guide basis, so that it's not an all or nothing choice that you have to make in every situation.

Locking any selected guide(s) is just like locking the position of any other object in InDesign. Select the guide(s) you'd like to lock and then use the Object > Lock Position command.



Managing ruler guides with layers

Once you've created and assigned colors to all your guides, there is another thing that InDesign can do for you to make working with ruler guides more efficient and more powerful. In InDesign you can assign ruler guides to different layers and then take advantage of the locking and visibility features.

1. Like any other object in InDesign, when you create an object in InDesign, it gets assigned to the active layer.

2. Also just like any other object. You can move selected guides from layer to layer. Click on the square object proxy in the later palette and drag it to the layer to which you desire to move the object.

3. Once you've got your ruler guides segregated to their desired layers, you can use each layer's visibility toggle to choose which sets of guides you want to see/use at any given time, without being distracted or confused by other guides you don't need at the time. If you typically use a lot of ruler guides in your layout, this can be a major benefit.

4. You can also lock ruler guides on a layer by layer basis easily by using the layer's locking toggle switch. This was you can quickly lock down some sets of guides, but keep some sets editable and adjustable.

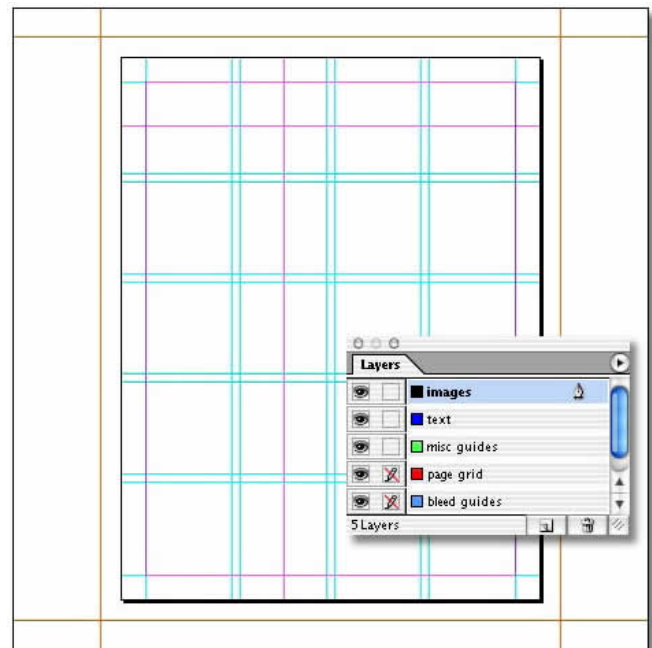
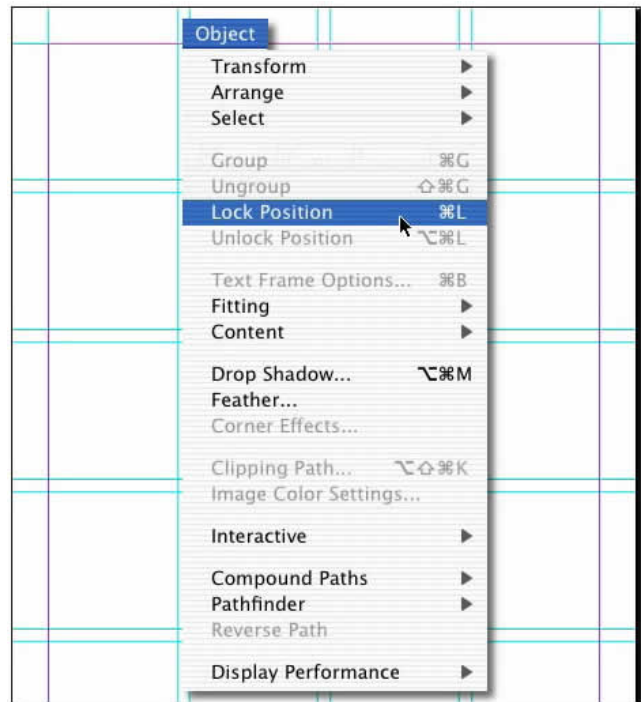

Using the Create Guides feature

InDesign makes it easy to quickly create page grids in documents. The Create Guides feature enables you to easily divide either the entire page area or the area within margins into rows and columns with user definable gutters. Different grids can live on different layers in your document or in your InDesign libraries.

1. Layout > Create Guides takes you to the Create Guides dialog box. Check the Preview box so that you can see your guides draw on the page as you modify the settings in the dialog.

2. Specify whether you want to fit the guides to the page or the margins, the number of rows and columns you want, and the desired gutter width.

3. If you want to remove existing ruler guides already on the page, check the box.

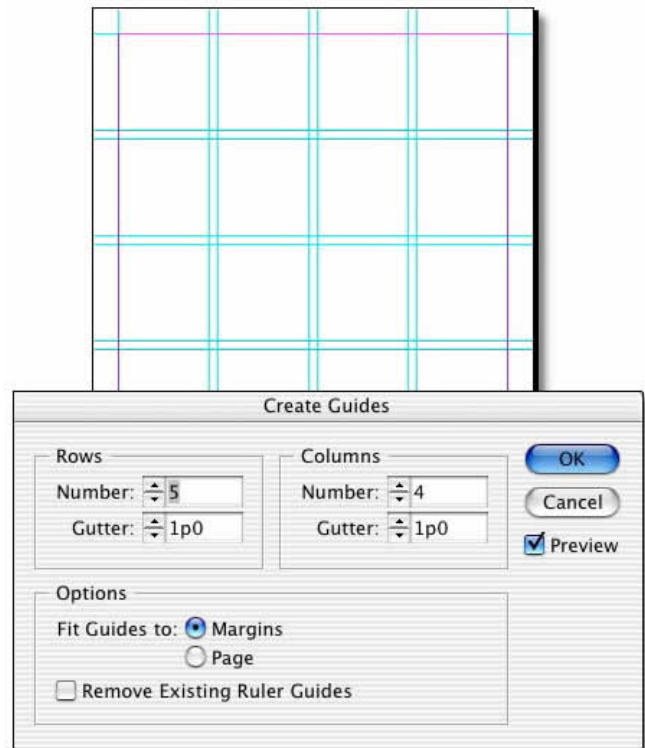

Note: this feature will only remove guides on visible layers. If you've got ruler guides you want to keep, turn off visibility for those layers, and then use Create Guides to remove the remaining visible guides.

Storing and placing guides using libraries

You can save sets of guides as elements in an InDesign library. This enables you to create the guides once, and then store them as reusable components for use in future layouts.

1. Select one or more guides in your layout.

2. Add guides to a library by using the Add Item command on the Library palette flyout menu.

3. To place guides in a library on a page, use the Place Items command on the same menu. The guides will be placed the same location that the page that they had when they were created and saved into the library.

Note: unlike other objects, you can't drag and drop ruler guides from a library, because they are always placed at their saved coordinates.

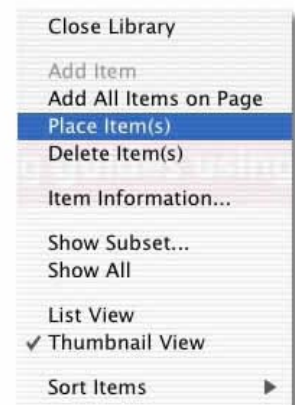
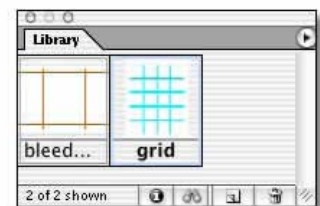
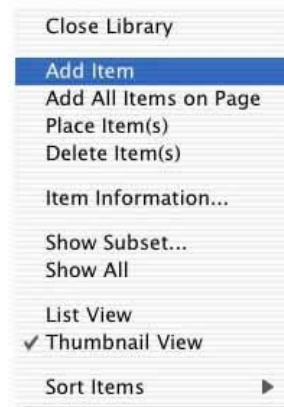

A most useful keyboard shortcut

If you'd like to select groups of guides in order to modify or delete them, InDesign has a keyboard shortcut to make it easy.

1. Make sure the guides you want to modify or delete are on visible, unlocked layers. If individual guides are locked, you'll be able to select them and copy them, or modify their color and layer assignment, but you won't be able to move or delete them. Also check to make sure the guides you want to select aren't on a master page. In order to use this shortcut, you'll need to jump to the master page itself.

2. Use `ctrl + alt + G` to select all the currently visible and editable guides on your page. Once selected, you can either delete them or modify them.

